

 **SUZUKI**[®]
SWIFT





ENGINE & PERFORMANCE

Engine: 1.2L Petrol (3-cylinder) | Engine Code: Z-Series (latest generation) | Displacement: 1,197 cc

Power: 82 HP @ 5,700 rpm | Torque: 111 Nm @ 4,300 rpm | Transmission: Automatic (CVT-type behavior)

Drivetrain: Front-Wheel Drive (FWD) | 0–100 km/h: ~11.5 sec | Fuel Economy: ~18–22 km/L (

CHASSIS & DRIVING

Platform: Lightweight HEARTECT platform

Front Suspension: MacPherson Strut

Rear Suspension: Torsion Beam

Steering: Electric Power Steering

Turning Radius: 4.8 m (excellent city use)

Driving Character: Agile / Urban-focused / Easy handling

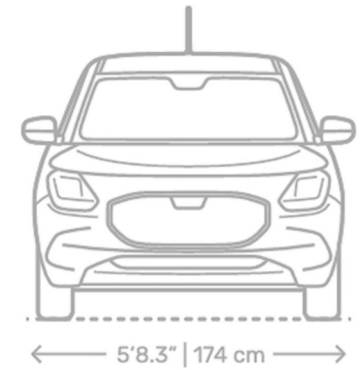
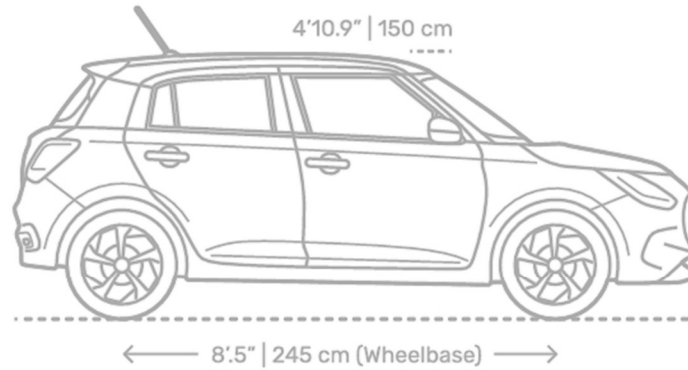

Plan

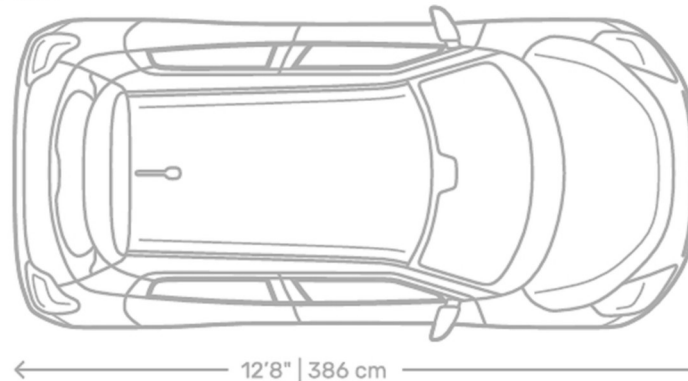

DIMENSIONS & CAPACITY

Seating: 5 passengers

Length: 3,860 mm

Width: 1,740 mm

Height: 1,520 mm

Wheelbase: 2,450 mm

Ground Clearance: 120 mm

Fuel Tank: 37L

Boot Capacity: up to 918L (seats folded)



INTERIOR & COMFORT

Premium fabric seats | Leather steering wheel | Keyless entry + Push Start

Automatic climate control | Rear AC vents | 60/40 split folding rear seats | Armrest + smart storage compartments





EXTERIOR

Color: Pure White

LED Headlights + DRL

LED Rear Lamps

Alloy Wheels (Sport Design)

Electric Folding Mirrors with indicators

Aerodynamic compact hatchback design





TECHNOLOGY & INFOTAINMENT

9-inch touchscreen display | Apple CarPlay & Android Auto | Navigation system | Rear-view camera | Bluetooth / USB connectivity

Multi-function steering wheel | Voice control