

TOYOTA

FORTUNER





ENGINE & PERFORMANCE

Engine: 2.7L Petrol, 4-Cylinder
Displacement: 2,694 cc
Power Output: 164 HP @ 5,200 rpm
Torque: 245 Nm @ 4,000 rpm
Transmission: 6-Speed Automatic
Drivetrain: Part-Time 4WD
with Transfer Case (HI/LOW)
Fuel Tank Capacity: 80L
Fuel Economy: ~10.3 km/L

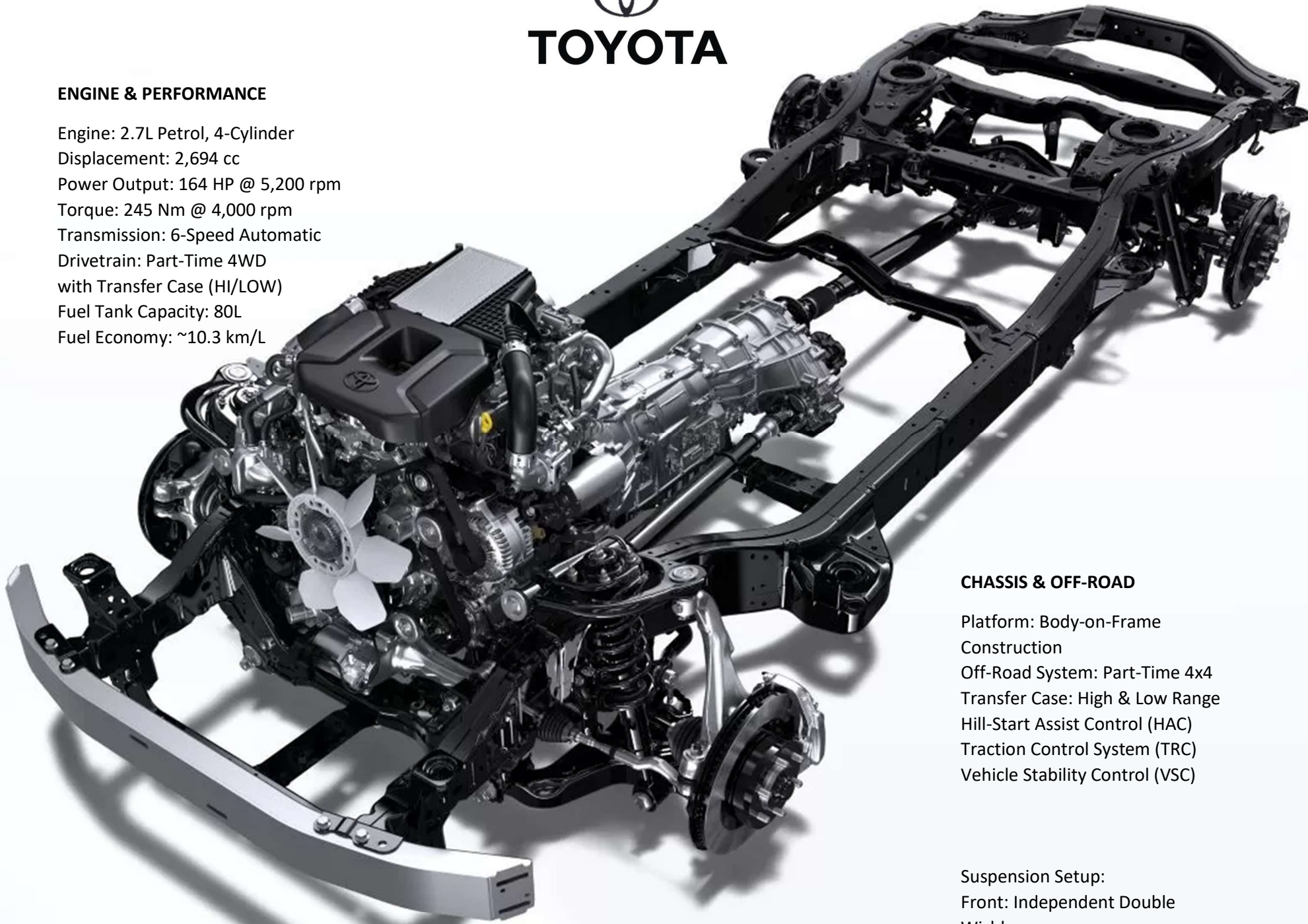

CHASSIS & OFF-ROAD

Platform: Body-on-Frame
Construction
Off-Road System: Part-Time 4x4
Transfer Case: High & Low Range
Hill-Start Assist Control (HAC)
Traction Control System (TRC)
Vehicle Stability Control (VSC)

Suspension Setup:

Front: Independent Double
Wishbone

Rear: 4-Link Rigid Axle



FORTUNER

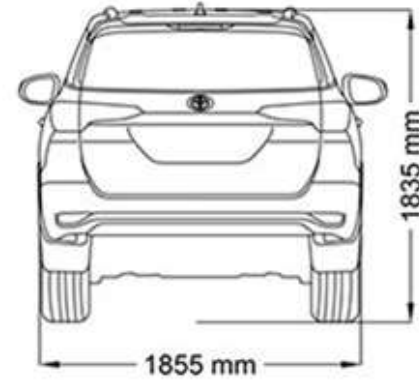
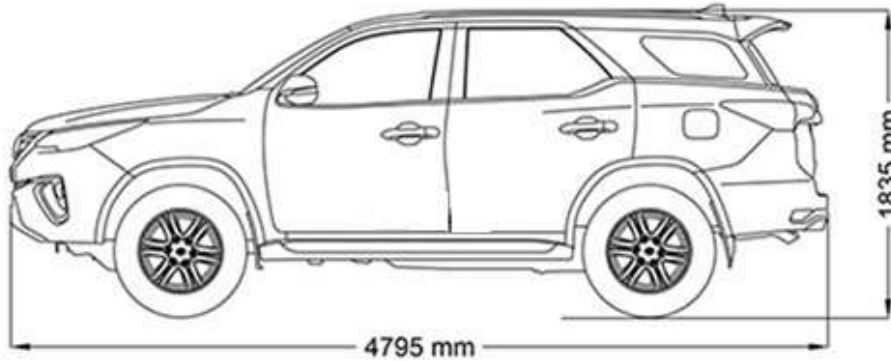
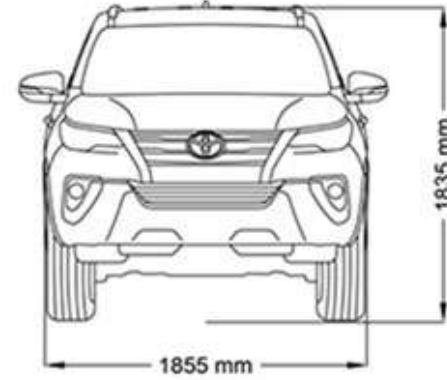
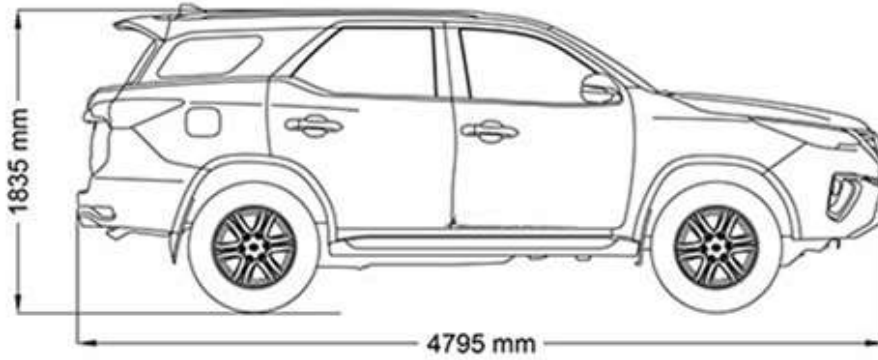

DIMENSIONS & CAPACITY

Length: 4,795 mm

Width: 1,855 mm

Height: 1,835 mm

Seating Capacity: 7 Passengers

Tire Size: 265/65R17



TOYOTA

FORTUNER



EXTERIOR FEATURES

- 17" Alloy Wheels
- LED Headlights
- Auto-Leveling Headlamps
- LED Daytime Running Lights (DRL)
- Side Steps
- Power Retractable Side Mirrors
- Colored Electric Mirrors with Turn Signal Lamps
- Chrome Outside Door Handles
- Grey Roof Rails
- Rear Spoiler

TOYOTA

FORTUNER

INTERIOR & COMFORT

Fabric Seats | Driver Seat Vertical Adjustment | Telescopic Steering Wheel | Steering Wheel Controls
Multi-Information Display | Manual Front Air Conditioning | Rear Manual Air Conditioning (Cooling Only)

FORTUNER

TOYOTA

AUDIO & INFOTAINMENT

8-inch Connected Display Audio (C-DA) Touchscreen | Apple CarPlay Compatibility
Digital Audio Broadcasting (DAB) Radio | Bluetooth Connectivity | 6-Speaker Audio System



SAFETY & DRIVER ASSIST

Driver & Front Passenger Airbags | Driver Knee Airbag | Anti-Lock Braking System (ABS) | Vehicle Stability Control (VSC)
Tire Pressure Warning System (TPWS) | Rear Parking Sensors | Rear View Camera

