

*TT Cars*



CULLINAN



Bespoke Dual Tone Exterior Paint  
Brown Metallic Body Finish  
Silver satin bonnet  
Hand-Painted Coachline  
Signature Rolls-Royce Silver Package Styling



# ROLLS-ROYCE CULLINAN





#### **ENGINE & PERFORMANCE**

Engine: 6.75L Twin-Turbocharged V12

Power Output: 563 HP

Torque: 850 Nm

Transmission: 8-Speed Satellite Aided Automatic Transmission

Drivetrain: Intelligent All-Wheel Drive (AWD)

Suspension: Self-Leveling Air Suspension

Rear Wheel Steering

Off-Road Capability System

0-100 km/h: ~5.2 Seconds



# ROLLS-ROYCE CULLINAN

### CHASSIS & DRIVING TECHNOLOGY

- Rolls-Royce Architecture of Luxury Platform
- Adaptive Air Suspension System
- Flagbearer Road Scanning Technology
- Satellite-Aided Transmission
- Active Roll Stabilization
- Hill Descent Control
- Electronic All-Terrain Driving Modes

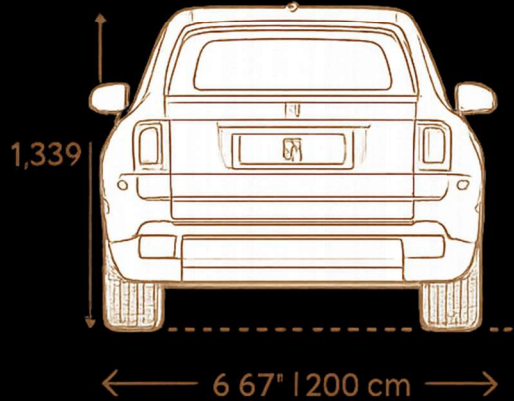
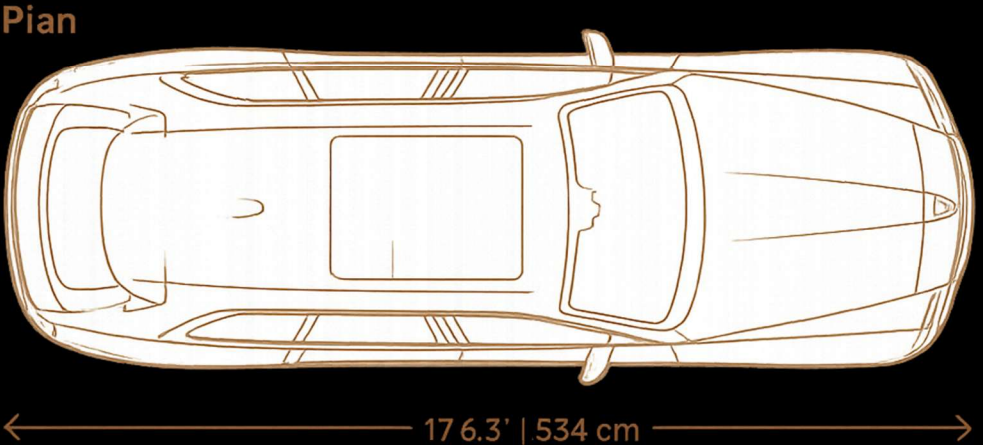
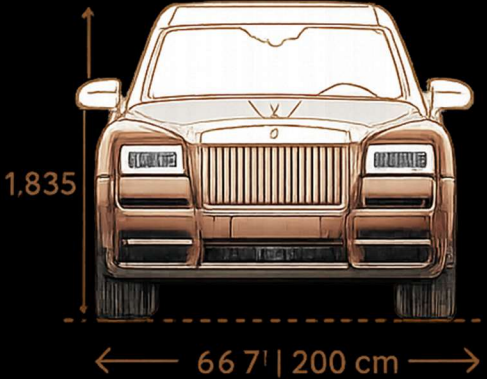
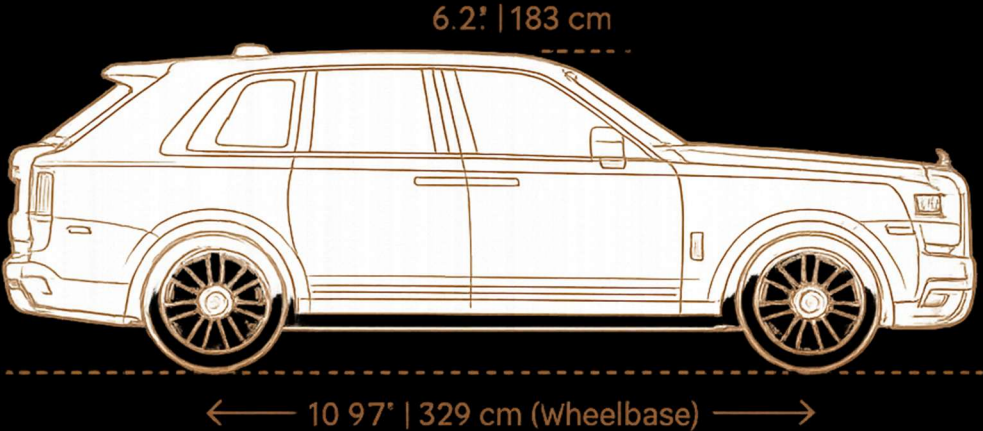

# ROLLS-ROYCE CULLINAN





 **Rear Viewing Suite**

The Cullinan's exclusive Viewing Suite transforms the rear cargo area into a private luxury lounge. Elegantly integrated into the tailgate, the electrically deployed seats feature the vehicle's bespoke dual-tone leather configuration, offering a refined open-air experience with unmistakable Rolls-Royce craftsmanship and comfort.